

Enter part #



Union, Low-Speed, 1-1/2" NPT RH, 3/4" NPT



1890-500

Duoflow design for low-speed air, hydraulic, and brake fluid 

Composite bearing

Vent holes between passages

Special seals

Hardened sealing surface

Aluminum housing and steel rotor

Triple-passage tandem model available

Imperial Metric

Dimensions

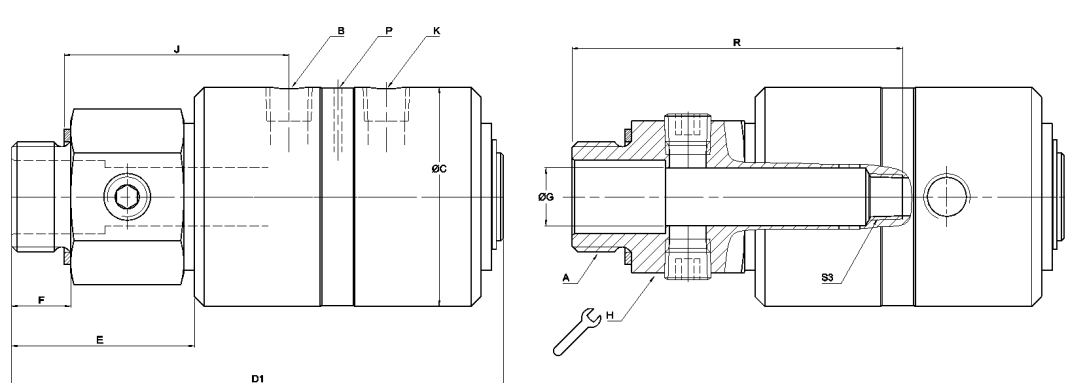
	
A	1-1/2"-11.5 NPT RH
B	3/4"-14 NPT
C	88.3 mm
D1	225.4 mm



G	20.6 mm
H	65 mm
J	104 mm
K	3/4"-14 NPT
P	Non-Threaded
R	156 mm
S3	Threaded

Operating Specifications

Media	Hydraulic Oil, Air
Rotor Connection	1-1/2"-11.5 NPT RH
Housing Connection	3/4"-14 NPT
Air Max. Flow	8497 l/min
Air Max. Pressure	10 bar
Air Max. Temperature	121 °C
Hydraulic Oil Max. Pressure	207 bar
Hydraulic Oil Max. Temperature	121 °C

